



## PRODUCT FEATURES

- Up to 11.1Gbps Data Links
- Up to 60km transmission on SMF
- Power dissipation <1.5W
- 1270 nm DFB laser and APD receiver for 10GSFP+-BD60-1270-LC
- 1330 nm DFB laser and APD receiver for 10GSFP+-BD60-1330-LC
- 2-wire interface with integrated Digital Diagnostic monitoring
- EEPROM with Serial ID Functionality
- Hot-pluggable SFP+ footprint
- Compliant with SFP+ MSA with LC connector
- Single + 3.3V Power Supply
- Case operating temperature: 0°C~+70°C

## APPLICATIONS

- 10GBASE-BX

## STANDARD

- Compliant with SFF-8472
- Compliant to SFF-8431
- RoHS Compliant

## PRODUCT DESCRIPTION

Hot pluggable 3.3V Small-Form-Factor transceiver module. It is designed expressly for high-speed communication applications that require rates up to 11.1Gb/s. The transceiver is compliant with SFF-8472 SFP+ MSA. The module data link is up to 60 km in 9/125um, single mode fiber.



## ORDERING INFORMATION

Product Part Number	Data Rate (Gbps)	Media	Wavelength (nm)	Transmission Distance (km)	Temperature Range (Tcase) (°C)	
10GSFP+-BD60-1270-LC	10.3125	Single mode fiber	1270/1330	60	-5~70	commercial
10GSFP+-BD60-1330-LC	10.3125	Single mode fiber	1330/1270	60	-5~70	commercial

## ABSOLUTE MAXIMUM RATINGS

Parameter	Symbol	Min.	Typ.	Max.	Unit	Note
Storage Temperature	Ts	-40	-	85	°C	
Storage Ambient Humidity	HA	5	-	95	%	
Operating Relative Humidity	RH	-	-	85	%	
Power Supply Voltage	VCC	-0.3	-	4	V	
Signal Input Voltage		Vcc-0.3	-	Vcc+0.3	V	

## RECOMMENDED OPERATING CONDITIONS

Parameter	Symbol	Min.	Typ.	Max.	Unit	Note
Case Operating Temperature	Tcase	-5	-	70	°C	Without air flow
Power Supply Voltage	VCC	3.14	3.3	3.47	V	
Power Supply Current	ICC	-		450	mA	
Data Rate	BR		10.3125		Gbps	
Transmission Distance	TD		-	60	km	
Coupled fiber	Single mode fiber					9/125um SMF



## OPTICAL CHARACTERISTICS

Parameter	Symbol	Min.	Typ.	Max.	Unit	Note
Transmitter						
Average Launched Power	PO	0	-	5	dBm	
Average Launched Power (Laser Off)	Poff	-	-	-30	dBm	Note (1)
Center Wavelength Range	$\lambda_C$	1260	1270	1280	nm	10GSFP+-BD60-1270-LC
		1320	1330	1340	nm	10GSFP+-BD60-1330-LC
Side mode suppression ratio	SMSR	30	-	-	dB	
Spectrum Bandwidth(-20dB)	$\sigma$	-	-	1	nm	
Extinction Ratio	ER	3.5		-	dB	Note (2)
Output Eye Mask	Compliant with IEEE 802.3ae					Note (2)
Receiver						
Input Optical Wavelength	$\lambda_{IN}$	1320	1330	1340	nm	10GSFP+-BD60-1270-LC
		1260	1270	1280	nm	10GSFP+-BD60-1330-LC
Receiver Sensitivity	Psen	-	-	-20	dBm	Note (3)
Input Saturation Power (Overload)	PSAT	-6	-	-	dBm	Note (3)
LOS -Assert Power	PA	-35	-	-	dBm	
LOS -Deassert Power	PD	-	-	-21	dBm	
LOS -Hysteresis	PHys	0.5	-	5	dB	

### Notes:

1. The optical power is launched into SMF
2. Measured with RPBS 2^31-1 test pattern @10.3125Gbs
3. Measured with RPBS 2^31-1 test pattern @10.3125Gbs BER=<10^-12



## ELECTRICAL INTERFACE CHARACTERISTICS

Parameter	Symbol	Min.	Typ.	Max.	Unit	Note
Total power supply current	Icc	-		450	mA	
Transmitter						
Differential Data Input Voltage	VDT	180	-	700	mVp-p	
Differential Line Input Impedance	RIN	85	100	115	Ohm	
Transmitter Fault Output-High	VFaultH	2.4	-	Vcc	V	
Transmitter Fault Output-Low	VFaultL	-0.3	-	0.8	V	
Transmitter Disable Voltage-High	VDisH	2	-	Vcc+0.3	V	
Transmitter Disable Voltage-Low	VDisL	-0.3	-	0.8	V	
Receiver						
Differential Data Output Voltage	VDR	300	-	850	mVp-p	
Differential Line Output Impedance	ROUT	80	100	120	Ohm	
Receiver LOS Pull Up Resistor	RLOS	4.7	-	10	KOhm	
Data Output Rise/Fall time	tr/tf		-	38	ps	
LOS Output Voltage-High	VLOSH	2	-	Vcc	V	
LOS Output Voltage-Low	VLOSL	-0.3	-	0.4	V	

## PIN DESCRIPTION

Diagram of Host Board Connector Block Pin Numbers and Name

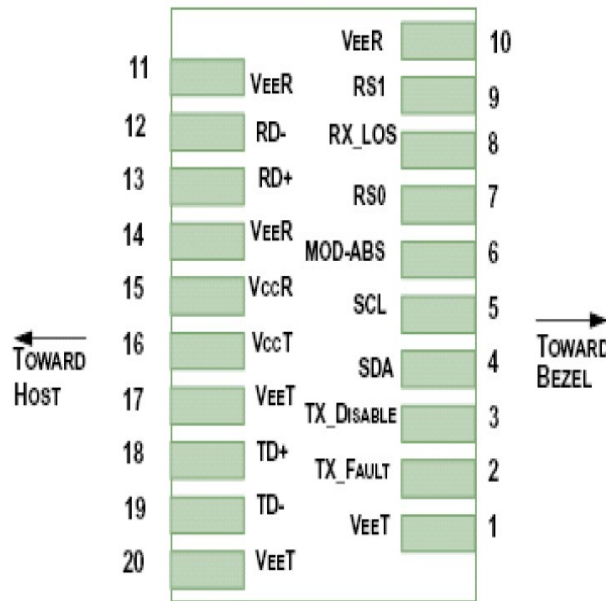

Pin	Symbol	Name/Description	NOTE
1	VEET	Transmitter Ground (Common with Receiver Ground)	1
2	TFAULT	Transmitter Fault	2
3	TDIS	Transmitter Disable. Laser output disabled on high or open.	3
4	SDA	2-wire Serial Interface Data Line	4
5	SCL	2-wire Serial Interface Clock Line	4
6	MOD_ABS	Module Absent. Grounded within the module	4
7	RS0	Rate Select 0	5
8	LOS	Loss of Signal indication. Logic 0 indicates normal operation.	6
9	RS1	No connection required	1
10	VEER	Receiver Ground (Common with Transmitter Ground)	1
11	VEER	Receiver Ground (Common with Transmitter Ground)	1



12	RD-	Receiver Inverted DATA out. AC Coupled	
13	RD+	Receiver Non-inverted DATA out. AC Coupled	
14	VEER	Receiver Ground (Common with Transmitter Ground)	1
15	VCCR	Receiver Power Supply	
16	VCCT	Transmitter Power Supply	
17	VEET	Transmitter Ground (Common with Receiver Ground)	1
18	TD+	Transmitter Non-Inverted DATA in. AC Coupled.	
19	TD-	Transmitter Inverted DATA in. AC Coupled.	
20	VEET	Transmitter Ground (Common with Receiver Ground)	1

Notes:

1. Circuit ground is internally isolated from chassis ground.
2. T<sub>FAULT</sub> is an open collector/drain output, which should be pulled up with a 4.7k – 10k Ohms resistor on the host board if intended for use. Pull up voltage should be between 2.0V to V<sub>cc</sub> + 0.3V. A high output indicates a transmitter fault caused by either the TX bias current or the TX output power exceeding the preset alarm thresholds. A low output indicates normal operation. In the low state, the output is pulled to <0.8V.
3. Laser output disabled on T<sub>DIS</sub> >2.0V or open, enabled on T<sub>DIS</sub> <0.8V.
4. Should be pulled up with 4.7kΩ- 10kΩ host board to a voltage between 2.0V and 3.6V. MOD\_ABS pulls line low to indicate module is plugged in.
5. Internally pulled down per SFF-8431 Rev 4.1.
6. LOS is open collector output. It should be pulled up with 4.7kΩ – 10kΩ on host board to a voltage between 2.0V and 3.6V. Logic 0 indicates normal operation; logic 1 indicates loss of signal.

### DIGITAL DIAGNOSTIC FUNCTIONS

10G transceivers support the 2-wire serial communication protocol as defined in the SFP+ MSA. The standard SFP serial ID provides access to identification information that describes the transceiver’s capabilities, standard interfaces, manufacturer and other information.



Additionally, SFP+ transceivers provide a unique enhanced digital diagnostic monitoring interface, which allows real-time access to device operating parameters such as transceiver temperature, laser bias current, transmitted optical power, received optical power and transceiver supply voltage. It also defines a sophisticated system of alarm and warning flags, which alerts end-users when particular operating parameters are outside of a factory set normal range.

The SFP+ MSA defines a 256-byte memory map in EEPROM that is accessible over a 2-wire serial interface at the 8-bit address 1010000X (A0h). The digital diagnostic monitoring interface makes use of the 8-bit address 1010001X (A2h), so the originally defined serial ID memory map remains unchanged.

The operating and diagnostics information is monitored and reported by a Digital Diagnostics Transceiver Controller (DDTC) inside the transceiver, which is accessed through a 2-wire serial interface. When the serial protocol is activated, the serial clock signal (SCL, Mod Def 1) is generated by the host. The positive edge clocks data into the SFP transceiver into those segments of the E2PROM that are not write-protected. The negative edge clocks data from the SFP transceiver. The serial data signal (SDA, Mod Def 2) is bi-directional for serial data transfer. The host uses SDA in conjunction with SCL to mark the start and end of serial protocol activation. The memories are organized as a series of 8-bit data words that can be addressed individually or sequentially.

## OUTLINE DIMENSIONS

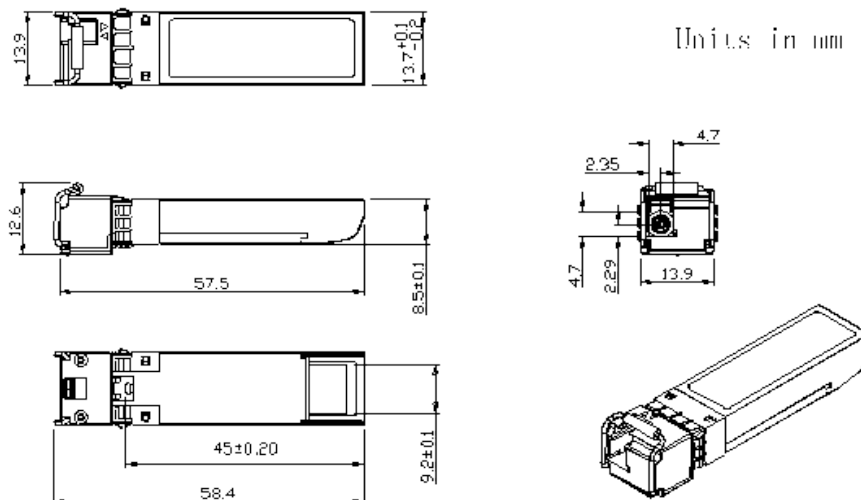



## REGULATORY COMPLIANCE

Feature	Reference	Performance
Electrostatic discharge (ESD)	IEC/EN 61000-4-2	Compatible with standards
Electromagnetic Interference (EMI)	FCC Part 15 Class B EN 55022 Class B (CISPR 22A)	Compatible with standards
Laser Eye Safety	FDA 21CFR 1040.10, 1040.11 IEC/EN 60825-1, 2	Class 1 laser product
Component Recognition	IEC/EN 60950 , UL	Compatible with standards
ROHS	2002/95/EC	Compatible with standards
EMC	EN61000-3	Compatible with standards